

Parts List				
ITEM	QTY	PART No.	DESCRIPTION	MATERIAL
1	1	BA4825	Ø80 SP Stab Body 10K Interv 2" fig. 1502 Fem ID 45 wJ-Lock	S165M
2	1	BA4726	Handle for Ø80 Stab with J-Lock	Assembly of 2.1 - 2.2
2.1	1	BA4796	Plate for D-Handle ver. 2	AISI 316L
2.2	1	BA4725	Swivel Ring for Ø80 SP Stab wWN	AISI 316L
3	2	BA2311	ROV Handle Bracket	AISI 316L
4	1	BA1823	J-Lock Bolt	AISI 316L
5	1	BA1306	Guide Nose Ø80	PEHD 1000
6	1	100987	Seal ring 2" 602 / 1002 / 1502 F Union	Rubber NBR
7	4	100253	M10x25 Socked Head Bolt DIN 912 A4-80	A4
8	2	100145	Ø80 Stab Seal	HPU/N270

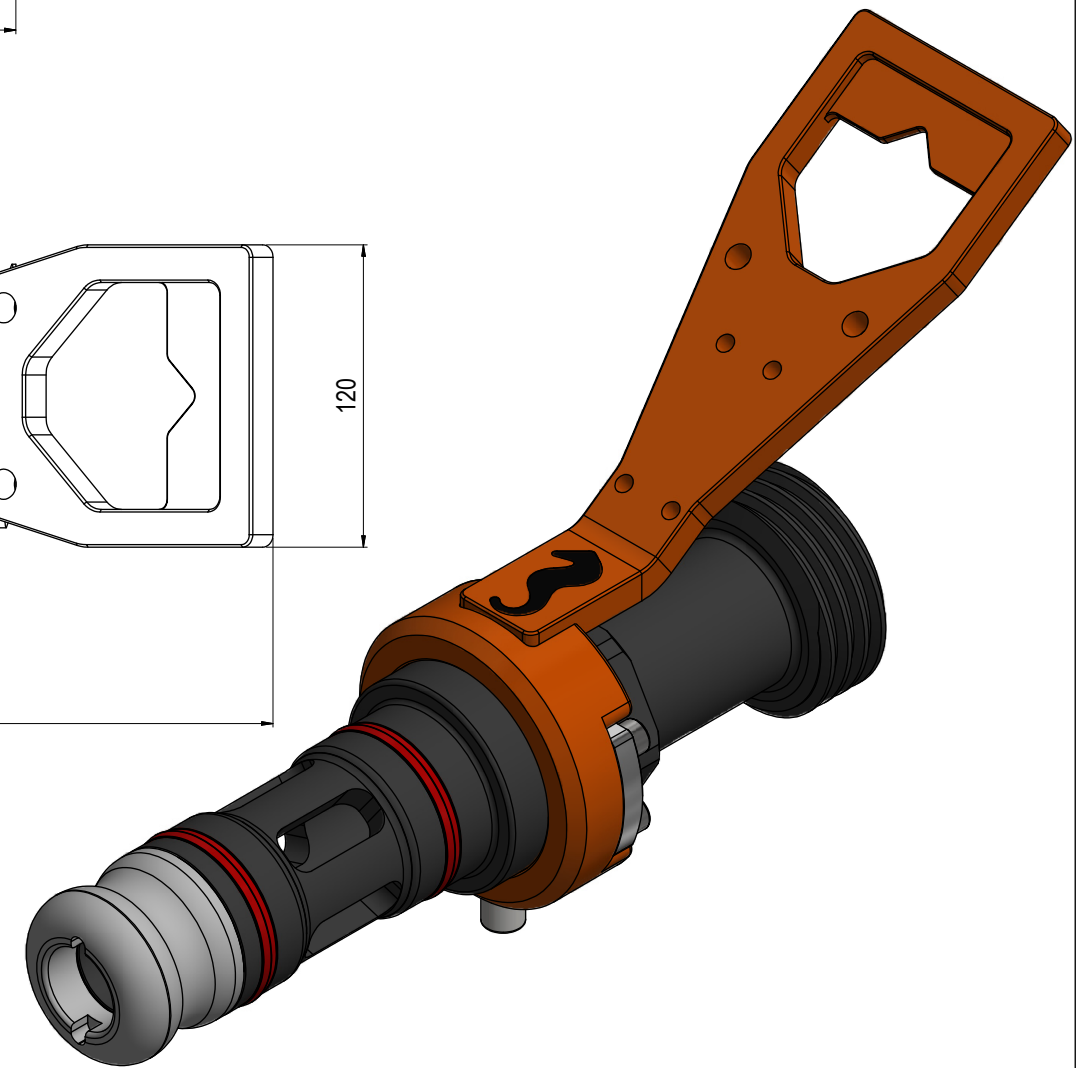
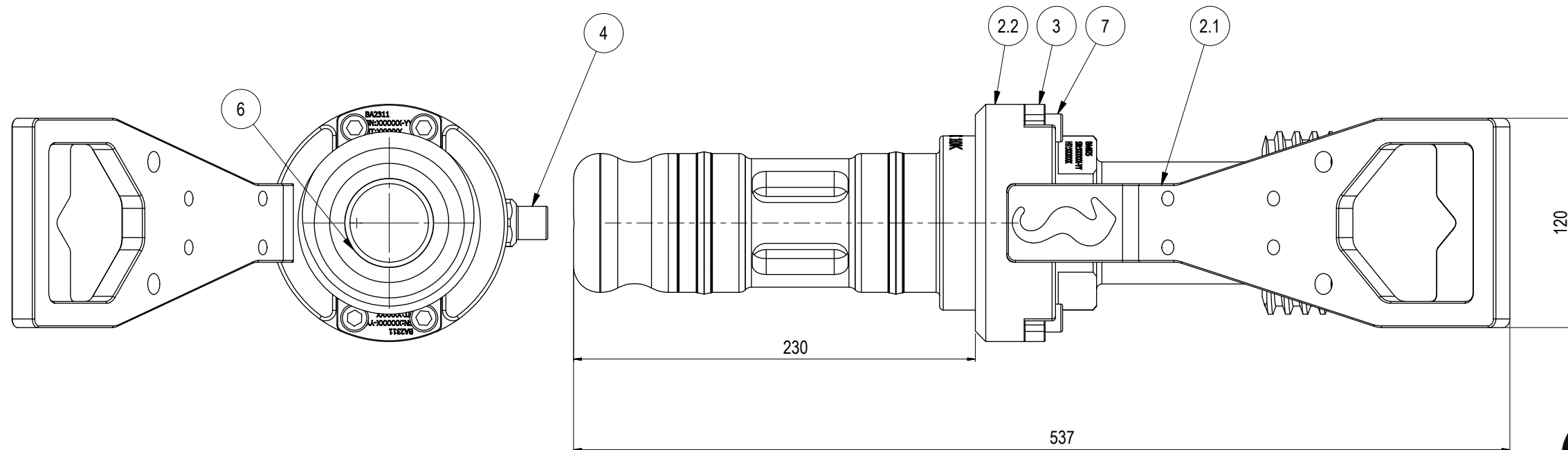
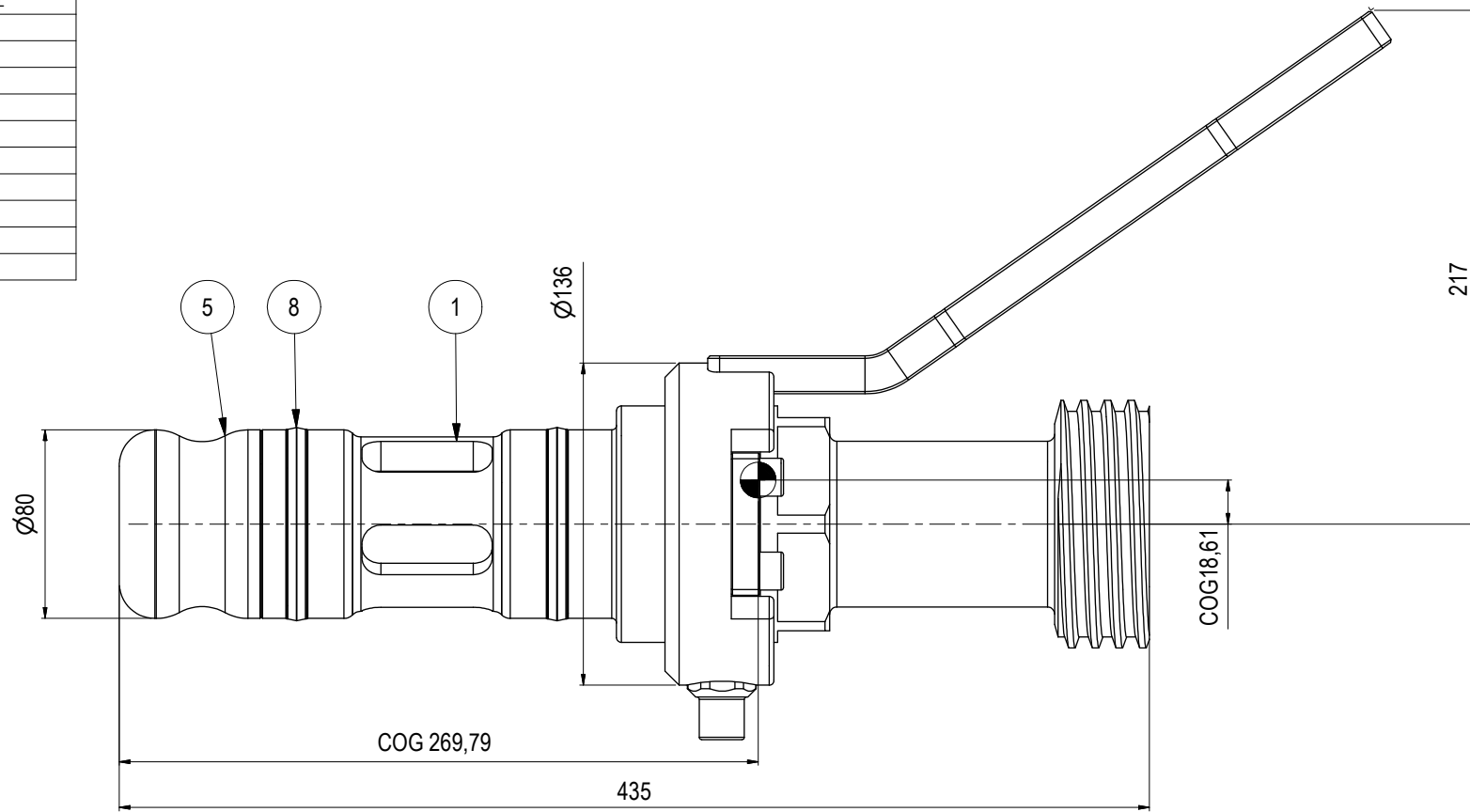

NOTE: 1
DESIGN CODE:
API 17H Type 4

NOTE: 2
TECHNICAL CLASSIFICATION:
Article Type: 001-Hot Stabs
Main Group: 1.05. Ø80 Hot Stab
Intermediate Group: 1.41.01. Stab
Sub Group: 1.41.99.01. Single

NOTE: 3
INTERFACE INFORMATION:
Pressure Rating Bar: 690
Material: Intervention
Weight: 15,7 kg
Volume: 2,17 dm³
Surface Area: 3733 cm²
Hydraulic: 2" fig. 1502 Female
Mechanical: N/A
Electrical: N/A
Com. & Protocol: N/A

NOTE: 4
SPAREPARTS:
BA5274

08	3.4.2023	9-IFU (Issued for Use)		HNJ	TAN	HNJ
07	30.8.2019	9-IFU (Issued for Use)		WTJ	LGH	WTJ
06	9.11.2017	9-IFU (Issued for Use)		WTJ	HNJ	WTJ
05	8.3.2016	9-IFU (Issued for Use)		HNJ	WTJ	HNJ
Rev.	Date	Reason for issue	Revision change	Made	Chk'd	Appr.

BLUE LOGIC

Dwg Scale:
NTS
Dwg Proj:
Dwg Format:
A3

Drawing title:
Ø80 SP Stab 10k Interv Weco 1502 Female 2" ID 45
wJ-Lock

Drawing number:
BA4826

Rev
08